

AGRAS MG-1S

MG-1S / MG-1S RTK

User Manual V1.0

2017.10

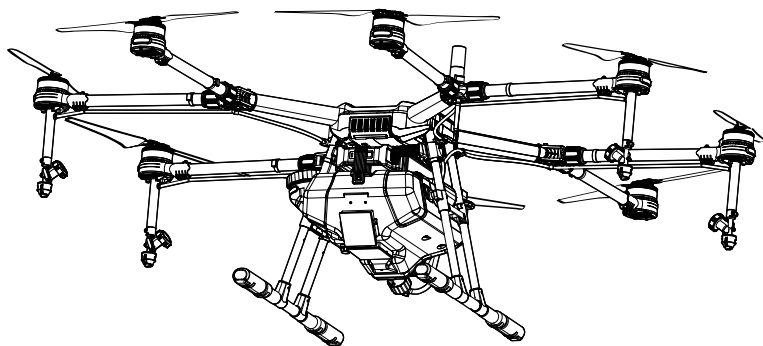

Searching for Keywords

Search for keywords such as “battery” and “install” to find a topic. If you are using Adobe Acrobat Reader to read this document, press Ctrl+F on Windows or Command+F on Mac to begin a search.

Navigating to a Topic

View a complete list of topics in the table of contents. Click on a topic to navigate to that section.

Printing this Document

This document supports high resolution printing.

Information

The AGRAS™ MG-1S / Agras MG-1S RTK does not come with a battery. Please purchase the DJI™ Designated Battery (Model: MG-12000S). Read the battery's safety guidelines and take necessary precautions when handling to ensure your own safety. DJI assumes no liability for damage(s) or injuries incurred directly or indirectly from misusing batteries.

Using This Manual

Legend

 Important

 Hints and tips

 Reference

Before Flight

The following manuals have been produced to help you get the most out of your Agras MG-1S / Agras MG-1S RTK:

1. In the Box
2. Disclaimer and Safety Guidelines
3. Quick Start Guide
4. User Manual

Refer to In the Box to check the listed parts, and read the Disclaimer and Safety Guidelines before flight. Refer to the Quick Start Guide and the video tutorial on the official DJI website to complete assembly and to learn basic operation. Please refer to the User Manual for more comprehensive information.

Watch the Tutorial Video

Please watch the tutorial video below to learn how to install and use the Agras MG-1S / Agras MG-1S RTK correctly:

<http://www.dji.com/mg-1s/info#video>



Download DJI Assistant 2

Download DJI ASSISTANT™ 2 from:

<http://www.dji.com/mg-1s/info#downloads>



Safety at a Glance

1. Pesticide Usage

- Pesticides are poisonous and pose serious risks to human safety. Please use them in strict accordance with their specifications.
- Residue on the equipment caused by splashes or spills when pouring and mixing the pesticide can irritate your skin. Be sure to clean the equipment after mixing.
- Use clean water to mix the pesticide to avoid blocking the strainer. Clear any blockages before using the equipment.
- Wear protective clothing to prevent direct body contact with the pesticide. Always rinse your hands and skin after handling pesticides. Clean the aircraft and remote controller after applying the pesticide.
- Effective use of pesticides relies on pesticide density, spray rate, spray distance, aircraft speed, wind speed and wind direction. Consider all factors when using pesticides, but NEVER compromise the safety of people, animals and the environment in doing so.
- DO NOT contaminate rivers and sources of drinking water.
- Avoid the use of powder pesticides as much as possible or else they may reduce the service life of the spraying system.



The AGRAS MG-1S / Agras MG-1S RTK (abbreviated as "MG-1S" / "MG-1S RTK") aircraft is NOT a toy and is not suitable for children under the age of 18.

Note that 'Safety at a Glance' only provides a quick overview of the safety tips. Make sure you read and understand the remaining sections of this document and the User Manual.

2. Environmental Considerations

- Always fly at locations that are clear of building and other obstacles.
- DO NOT fly above or near large crowds.
- Avoid flying at altitudes above 164 feet (50 m).
- Be very careful when flying over 6,560 feet (2,000 m) above sea level.
- Fly in moderate weather conditions with temperatures between 32° to 104° F (0° to 40° C).
- DO NOT operate any parts of the aircraft indoors.

3. Pre-flight Checklist

- Remote controller and aircraft batteries are fully charged.
- Landing gear and spray tank are firmly in place.
- All screws are firmly tightened.
- Propellers and frame arms are unfolded, and arm sleeves are firmly tightened.
- Propellers are in good condition and firmly tightened.
- There is nothing obstructing the motors.
- Spraying system is without any blockage and works properly.
- Compass is calibrated at every new flight location.

4. Operation

- Stay away from the rotating propellers and motors.
- The takeoff weight must not exceed 24.8 kg (taking off at sea level).
- Maintain a visual line of sight (VLOS) to your aircraft at all times.
- DO NOT use the Combination Stick Command (CSC) or other methods to stop the motors when the aircraft is airborne unless in an emergency situation.
- DO NOT answer incoming calls during flight.
- DO NOT fly under the influence of alcohol or drugs.
- During the Return-to-Home procedure, you can adjust the altitude to avoid obstacles.
- In the instance of a Low Battery Warning, land the aircraft at a safe location.
- After landing, first stop the motors, then power off the aircraft, and then turn off the remote controller.
- Please maintain full control of the aircraft at all times and do not rely on the DJI MG app. Please keep the aircraft within your visual line of sight and visually observe the flight. Please use your sound discretion to operate the aircraft and avoid obstacles timely and manually. It is important to set an appropriate Failsafe and Return-to-Home altitude before each flight.

5. Maintenance and Upkeep

- DO NOT use aged, chipped or broken propellers.
- Remove or empty the spray tank during transportation or when not in use to avoid damaging the landing gear.
- Recommended storage temperature (empty spray tank): between -4° and 104° F (-20° and 40° C).
- Clean the aircraft immediately after spraying.
- Inspect the aircraft every 100 flights or after flying for over 20 hours.
- For more maintenance guidelines, refer to the Product Care section in this document.

6. Observe Local Laws and Regulations

- DO NOT fly in any No Fly Zones. You can find a list of these areas at <http://www.dji.com/flysafe/no-fly>
- The DJI No Fly Zone is not a replacement for local government regulations or good judgment.
- Avoid flying in areas where rescue teams are actively using the airspace.



Fly in Open Areas

Calibrate the
Compass

Strong GPS Signal

VLOS

Fly Below 164 feet (50 m)



Avoid flying over or near crowds, high voltage power lines or bodies of water. Strong electromagnetic sources such as power lines, base stations, and tall buildings may affect the onboard compass. It is recommended to use MG-1S RTK. Always stay alert about surroundings in flight.



DO NOT use the aircraft in adverse weather conditions such as rain (precipitation rate exceeding 25 mm or 0.98 inches in 12 hours), wind speeds exceeding 8 m/s or 17 mph (28 kph), fog, snow, and lightning.

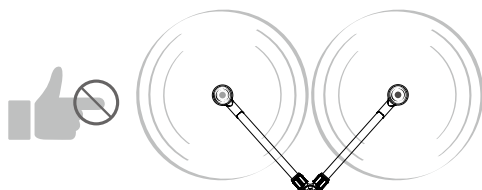

Stay away from the rotating
propellers and motors.



No Fly Zone

Learn more at:
<http://www.dji.com/flysafe/no-fly>

Content

Information	3
Using This Manual	3
Legend	3
Before Flight	3
Watch the Tutorial Video	3
Download DJI Assistant 2	3
Safety at a Glance	4
Profile	9
Introduction	9
Feature Highlights	9
Overview	10
Installation	13
Mounting the Hose Clip	13
Mounting the Landing Gear	13
Mounting the Spray Tank	14
Mounting the Power Port Modules	14
Mounting the Sprinklers	16
Unfolding the Frame Arms	16
Mounting the Battery	17
Mounting the USB Stick	18
Remote Controller	19
Profile	19
Using the Remote Controller	19
Remote Controller LEDs	25
Linking the Remote Controller	26
The DJI MG App	27
Main Interface	27
Operation View	28
Intelligent Operation Planning System	30

Aircraft	32
Profile	32
Operation Modes	32
Operation Resumption	35
System Data Protection	37
Radar Terrain Follow System	37
Empty Tank Warning	38
Return to Home (RTH)	39
Low Battery Warnings	41
RTK Functions (for MG-1S RTK only)	41
Flight	42
Operation Environment	42
Flight Limits and No-Fly Zones	42
Pre-Flight Checklist	44
Calibrating the Compass	44
Calibrating the Flow Meter	45
Starting and Stopping the Motors	46
Flight Test	47
DJI Assistant 2	48
Installation and Launching	48
Using DJI Assistant 2	48
Appendix	50
Specifications	50
Aircraft Status Indicator Description	52
Upgrading the Firmware	53

Profile

Introduction

The Agras MG-1S / Agras MG-1S RTK (abbreviated as “MG-1S” / “MG-1S RTK”) is a battery-powered multirotor aircraft designed for agricultural applications in variety of environments and terrains, including fields, forests and orchards. It is dust-proof, water-proof (IP43 protection rating, IEC standard 60529) and made of anti-corrosive materials, allowing it to be rinsed clean.

The MG-1S / MG-1S RTK contains DJI’s dedicated A3 redundancy system with dual IMU and dual compass capabilities, ensuring safe and stable operation at all times. The MG-1S RTK has a built-in DJI Onboard D-RTK*, which provides more accurate data for centimeter-level positioning. F-mode, uses the DJI MG app for automatic intelligent flight planning. Radar Terrain Follow, consists of three radar modules, one on the front, rear, and underside of the aircraft, measuring distances from all three directions for terrain follow applications.

The remote controller is equipped with a bright, dedicated screen with a built-in Android system that runs the DJI MG app independently. The app features intelligent operation planning functions to produce flight routes automatically, according to marked operation areas and obstacles. The DJI MG app is able to display the system status, convenient when your aircraft is spraying far away from you.

Feature Highlights

The MG-1S uses a DJI dedicated flight control system, providing three operation modes: Smart, Manual, and Manual Plus. This system also includes three flight modes: P-mode (Positioning), A-mode (Attitude), and F-mode (Function).

In Smart operation mode, the aircraft will travel along a pre-planned route and spray its liquid payload. Users can set the line spacing, flying speed, and other parameters. The MG-1S can cover an area of 7-10 acres per hour.

In Manual operation mode, users can start and stop spraying manually and also adjust the spray rate.

In Manual Plus operation mode, flight speed is restricted and heading is locked. Except for the heading, users can control the aircraft’s movement via control sticks. Press button C1/C2 and the aircraft will fly one line spacing to the left/right.

The DJI MG app will automatically produce flight routes based on your planned tasks, which the aircraft will perform once in F-mode.

The MG-1S also includes two intelligent memory features: Operation Resumption and System Data Protection. When the operation or flight mode is changed from Smart operation mode or F-mode, Operation Resumption records a set return point for the aircraft when Smart Operation Mode is reinstated. System Data Protection keeps system data for 30 seconds, even when powered off, so users can resume their missions after replacing the battery.

The spraying system includes a spray tank, flow meter, liquid level meter, sprinklers, and other accessories. The four sprinklers placed on the aircraft’s two sides provide evenly distributed spraying and coverage of the liquid payload. The nozzles on the MG-1S / MG-1S RTK can also be swapped out to meet the needs of different applications.

An advanced Radar Terrain Follow System consists of three radar modules located on the front, rear, and underside of the aircraft. It works automatically in Smart or Manual Plus operation mode or F-mode.

The MG-1S RTK has a built-in DJI Onboard D-RTK, providing more accurate data for centimeter-level positioning when used with the DJI D-RTK Base Station. An optional DJI D-RTK Handheld Mapper is designed for more precise field planning, enhancing agricultural operations with the Intelligent Operation Planning System within the DJI MG app.

* This should be used with a DJI D-RTK™ Base Station (purchased additionally). Refer to [RTK Functions](#) (p. 41) for details.

Overview

Aircraft

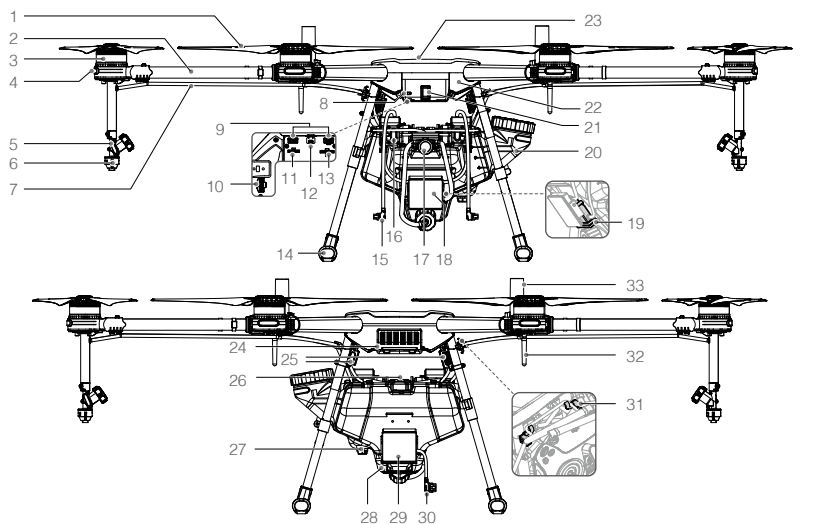

- | | | |
|------------------------------|---|--|
| 1 Propellers | 13 Reserved Expansion Port 2 | 24 Intake Vent (front of the aircraft) |
| 2 Frame Arms | 14 Landing Gear | 25 Power Ports |
| 3 Motors | 15 Pump Cables | 26 Battery Compartment |
| 4 Orientation LEDs | 16 Delivery Pumps | 27 Liquid Level Meter |
| 5 Sprinklers | 17 Flow Meter | 28 Downward Radar Module |
| 6 Nozzles | 18 Rear Radar Module | 29 Forward Radar Module |
| 7 Hoses | 19 Buffer Tank | 30 Radar Cable |
| 8 Link Button | 20 Spray Tank | 31 Remote Controller Holder |
| 9 Pump Ports | 21 Aircraft Status Indicator (rear of the aircraft) | 32 Datalink Pro Antennas |
| 10 Reserved Expansion Port 1 | 22 Aircraft Body | 33 Onboard D-RTK Antennas (for MG-1S RTK only) |
| 11 Radar Port | 23 Built-in GPS Module | |
| 12 Micro USB Port | | |



- DO NOT obstruct the GPS module located at the center of the aircraft, as this will reduce the GPS signal strength.
- The MG-1S / MG-1S RTK does not come with a battery. Please purchase the DJI approved MG-1S battery pack (Model: MG-12000S).

Remote Controller

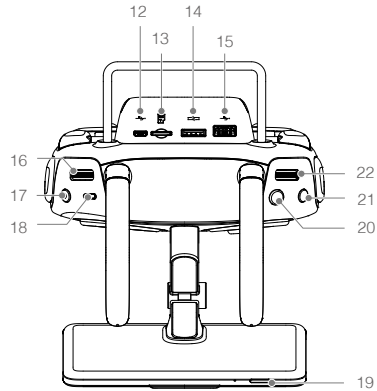
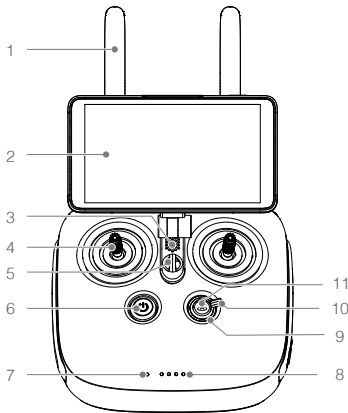

1 Antennas

Relays aircraft control signals.

2 Display Device

Android-based to run the DJI MG app.

3 Speaker

Audio output.

4 Control Sticks

Controls aircraft movement. Can be set to Mode 1, Mode 2, or a custom mode.

5 Lanyard Attachment

Used to attach the remote controller lanyard.

6 Power Button

Used to turn the remote controller on and off.

7 Status LED

Indicates whether the remote controller is linked to the aircraft.

8 Battery Level LEDs

Displays current battery level.

9 RTH Status LED

Circular LED around the RTH button. Displays RTH status.

10 Operation Mode Switch

Used to switch between Smart, Manual, and Manual Plus operation modes.

11 RTH Button

Press and hold this button to initiate Return to Home (RTH).

12 Micro USB Port

Reserved.

13 Micro SD Card Slot

Provides display device with up to 128 GB of extra storage.

14 CAN Port

Used to connect other accessories, such as a GPS module.

15 USB Port

Used for upcoming functions.

16 Spray Rate Dial

Turn to adjust the spray rate in both Manual and Manual Plus operation modes.

17 Spray Button

Press to start/stop spraying in Manual operation mode.

18 Flight Mode Switch

Used to switch among P, A, and M flight modes.

19 Sleep/Wake Button

Press to sleep/wake the screen; press and hold to restart.

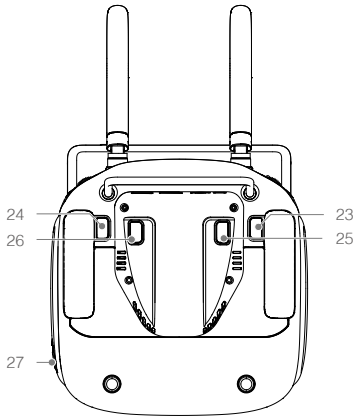

- 20 Button A**
Records Point A of the operation route.
- 21 Button B**
Records Point B of the operation route.
- 22 Settings Dial**
Turn to adjust work efficiency in Smart operation mode or F-mode.

- 23 Button C1**
Press to choose operation route L in Smart operation mode. Press to fly the aircraft one line spacing to the left in Manual Plus operation mode. Press to start or end obstacle measurements when planning a task.
- 24 Button C2**
Press to choose operation route R in Smart operation mode. Press to fly the aircraft one line spacing to the right in Manual Plus operation mode. Press to add a waypoint when planning a task.
- 25 Button C3**
Press to use the front two sprinklers only in Manual operation mode. Press to add a calibration point when planning a task.
- 26 Button C4**
Press to use only the rear two sprinklers in Manual operation mode.
- 27 Power Port**
Connects to a power source to charge the remote controller's internal battery.

Installation

- ⚠ Threadlocker is required for installation. Apply threadlocker when mounting the landing gear, spray tank, sprinklers and power port modules. Ensure threadlocker is totally dry and solid before flight.
- DO NOT bend the hose in an arc tighter than its minimum bend radius during installation. This is to avoid creasing, which may compromise the spraying effect.
- Ensure that all installation and connection procedures are completed before powering on the aircraft.

Installation steps are the same for both the MG-1S and MG-1S RTK. The illustrations below use the MG-1S as an example.

Mounting the Hose Clip

Mount the self-adhesive hose clip to the outside of the right landing gear leg mounting position (as shown) and tighten the M3x6 screw.

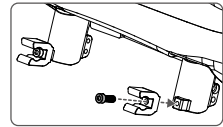

Mounting the Landing Gear

1. Identify the landing gear leg containing the two compass cables.
2. Take out each compass cable from the tube of the landing gear leg. Looking from the rear of the aircraft, connect each compass cable to the compass port on the right side of the aircraft body. Put the assembled cable into the cable protector slot and close it. Be careful not to damage the cable.
3. Place each cable protector and cable into its corresponding mounting position on the aircraft body then mount the right landing gear leg to the mounting position.
4. Insert the two anti-drop plates into the mounting position and tighten the three M3x10 screws.

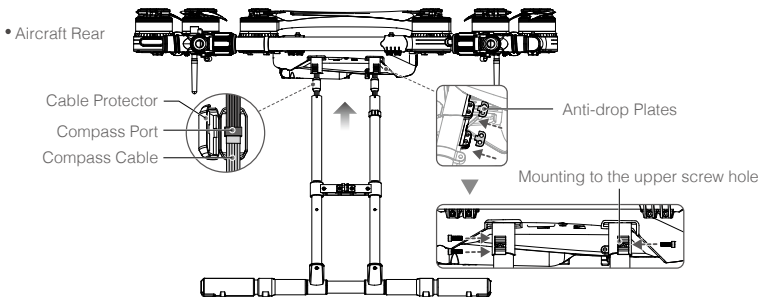

5. Mount the left landing gear leg and tighten the three M3x10 screws.

Mounting the Power Port Modules

Mount the two power port modules on the bottom of the aircraft onto the two landing gear legs and tighten the two M3×18 screws and one M3×22 screw.

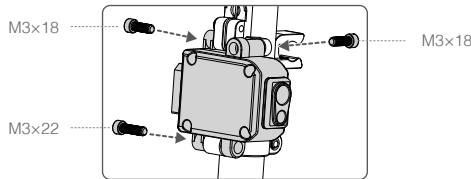

Mounting the Spray Tank

1. Connect the sprinkler kits to the spray tank.

- ① Remove the nuts on the left and right delivery pump outlets and pull the white hose on the T connector through the nut to the left outlet. Pull the black hose on the T connector through the nut to the right outlet, then tighten both nuts using an appropriate wrench. Be sure to securely tighten the nuts to avoid liquid leakage.
- ② Remove the nut on the T connector then pull the white (or black) hose with a sprinkler through the nut to the T connector with a white (or black) hose. Tighten the nut using an appropriate wrench.
- ③ Insert the two T connectors of the two sprinkler kits into the slots between the two delivery pumps. Note that the T connector with a white hose should be under the one with a black hose.

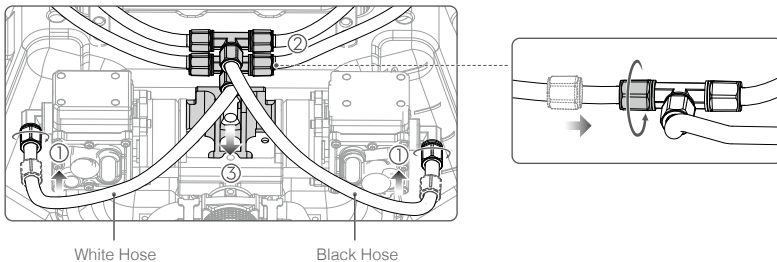

2. Prepare hose clamps B and M4×8 screws to fix the hoses to both sides on top of the spray tank.

- ① Open hose clamps B to an appropriate angle gently. DO NOT over-stretch the clamps to avoid damage.
- ② Clip the clamps around a white hose (outer position) and a black hose (inner position) at positions that need to be fixed. Ensure the flat side of the clamp is close to the spray tank, then tighten the M4×8 screw.

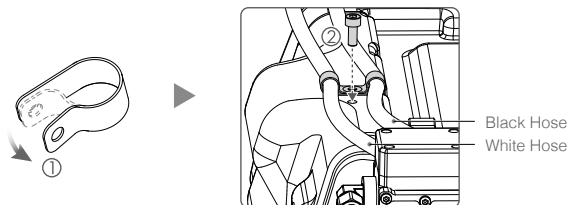

3. Remove the cover of the spray tank. Looking from the rear of the aircraft, pull the hoses on both sides through the space between the two tubes of the landing gear leg with the mouth of the tank facing to the right side of the aircraft.
4. Lift the spray tank and pull the mouth of the tank through the space between the two tubes of the right landing gear leg.

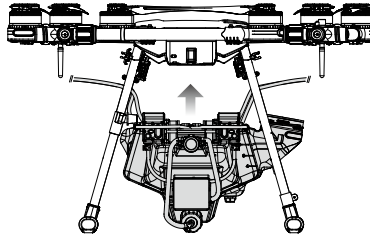

5. Insert the plugs on the left landing gear leg into the mounting holes on the spray tank.
6. Slide the fixing part on the right landing gear leg to the marks on the tube to align the screw holes on the fixing part and the fin on the right side of the spray tank. Then tighten the two M3x12 screws and one M3x10 (Plus) screw.

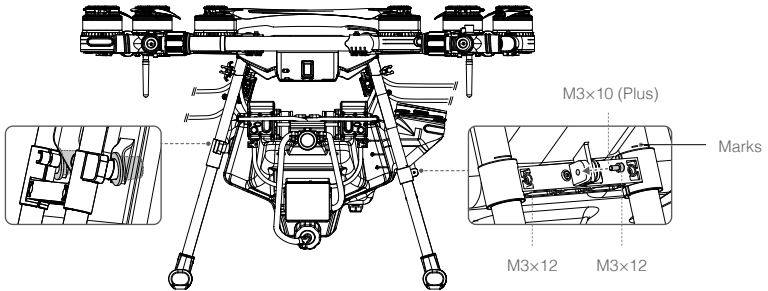

7. Connect each of the two pump cables to the pump port on the aircraft body.
8. Connect the radar cable to the radar port on the aircraft body.

Unfolding the Frame Arms

1. Unfold the frame arms ① and tighten the two arm sleeves at each of the junctions ②.
2. Identify the position and rotational direction of the motors. The top view shows motors M1 to M8 arranged in a counter-clockwise order, with motors M1 and M2 at the front of the aircraft, and motors M5 and M6 at the rear. Motors M1, M3, M5 and M7 rotate counter-clockwise as indicated by the "CCW" mark, while motors M2, M4, M6 and M8 rotate clockwise as indicated by the "CW" mark.

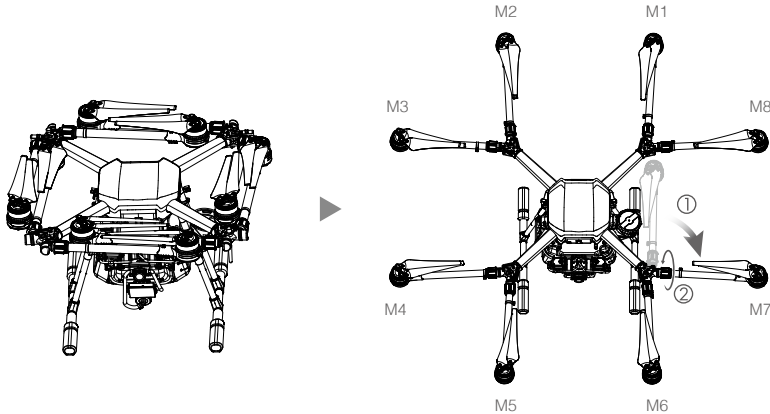

Mounting the Sprinklers

1. Mount the sprinklers with white hoses under motors M3 and M8. Mount the sprinklers with black hoses under motors M4 and M7. Mount each of the four sprinklers using three M3x5 screws.
2. Prepare hose clamps B and T3x8 screws to fix the hoses to the frame arms.
 - ① Open hose clamps B to an appropriate angle gently. DO NOT over-stretch the clamps to avoid damage.
 - ② Clip the clamps around the hoses at the position that needs to be fixed. Ensure that the flat side of the clamp is close to the bottom of the frame arm junction and tighten the T3x8 screw.

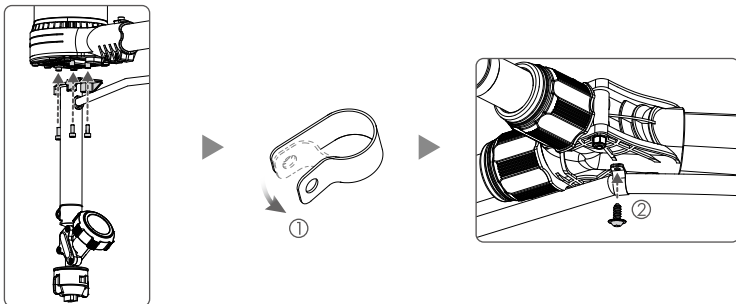

3. Insert the hoses on both sides into the clips on the landing gear.

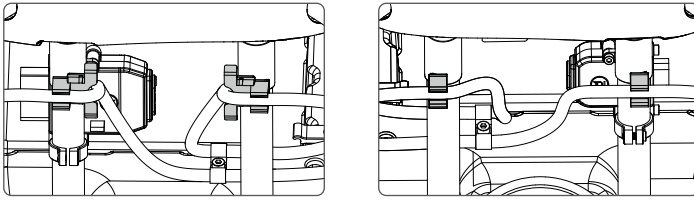

4. Mount the fender to the right landing gear leg to avoid spills when pouring liquids. Handle with care to avoid damage to the fender.

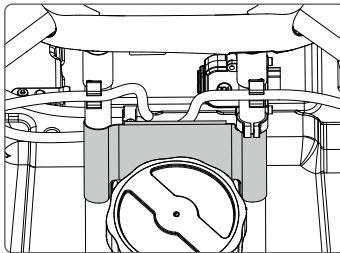

Mounting the Battery

Insert the battery into the battery compartment from the front of the aircraft. Ensure the battery is securely mounted and then buckle the belt to the button of the spray tank.

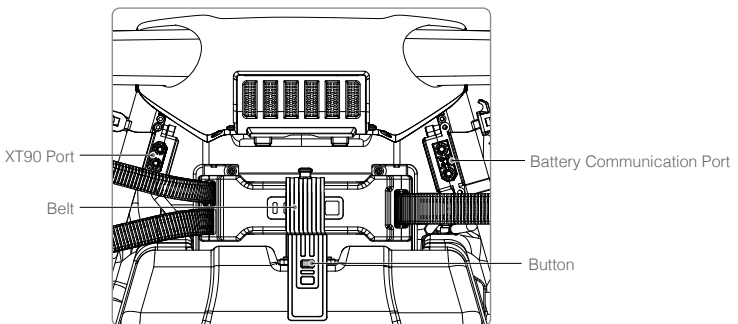

- The MG-1S / MG-1S RTK does not come with a battery. Please purchase the DJI approved MG-1S battery pack (Model: MG-12000S).
- The voltage on the aircraft can reach 50.4 V. Read the battery's safety guidelines and take necessary precautions when handling the battery to ensure your own safety.

Mounting the USB Stick

The USB stick is used for the display device of the remote controller to allow access to specific networks (such as connecting to the DJI Agriculture Management Platform, etc.). Be sure to mount it correctly onto the remote controller, or else the related services cannot be used.

1. Remove the four screws and the cover on the back of the remote controller.
2. Insert the SIM card into the USB stick correctly and then connect the USB stick to the USB port inside the remote controller. Test to ensure that they function properly.*
3. Re-mount the cover and tighten the screws.

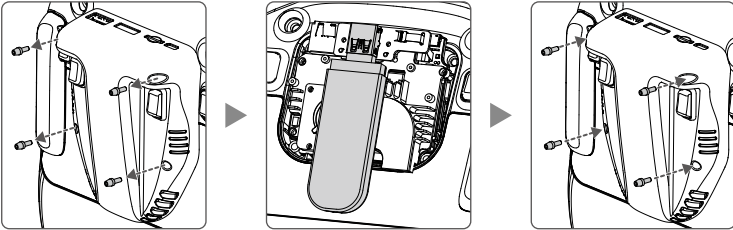

- Be sure to use a DJI approved USB stick.
- Use the USB stick and the SIM card according to their manuals.

* Test procedure: Press once, again and hold the power button of the remote controller to turn it on. Go to DJI MG app > ⚙️ > Network Diagnostics. If the "DJI Agriculture Management Platform" is "Normal", it indicates that the USB stick and SIM card are working properly.

Remote Controller

Profile

The aircraft remote control system operates at 2.4 GHz. It includes a dedicated, Android-based display that runs the DJI MG app independently for operation planning and aircraft status display. Additional controls include spraying system control buttons, dials, and an operation mode switch to help complete tasks in each operation mode.

 Stick mode can be set to Mode 1, Mode 2, and Mode 3, or to a custom mode in the DJI MG app.

 Avoid using wireless devices that use the same 2.4 GHz frequency band as the remote controller. To prevent transmission interference, do not operate more than three aircraft in the same area.

Using the Remote Controller

Turning the Remote Controller On and Off

The remote controller is powered by a 6000 mAh 2S rechargeable battery. The battery level is indicated via the Battery Level LEDs on the front panel. Follow the steps below to turn on your remote controller:

1. When the remote controller is turned off, press the Power button once to check the current battery level, indicated by the Battery Level LEDs. If the battery level is too low, recharge before use.
2. Press the Power button once. Then press and hold to turn on the remote controller.
3. The remote controller will beep when turned on. The Status LED will rapidly blink green, indicating that the remote controller is linking to the aircraft. They will glow solid green when linking is complete.
4. Repeat Step 2 to turn off the remote controller.

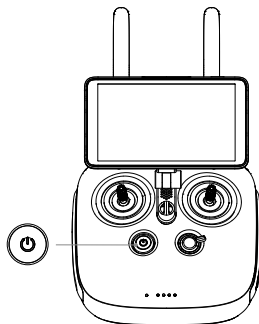

Charging the Remote Controller

Charge the remote controller using the included charger. Refer to the figure below for more details:

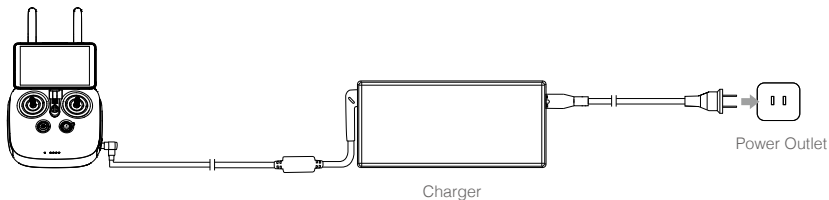

Operating the Aircraft

This section explains how to control the orientation of the aircraft through the remote controller. Control can be set to Mode 1, Mode 2 or Mode 3, or to a custom mode.

Mode 1

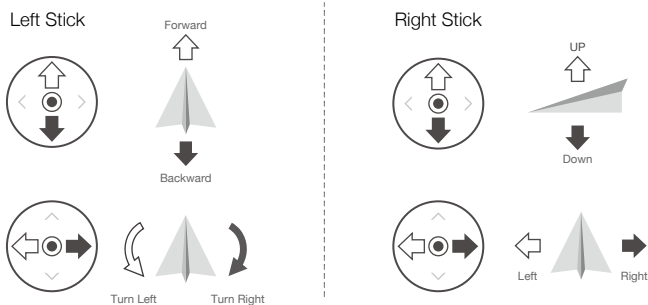



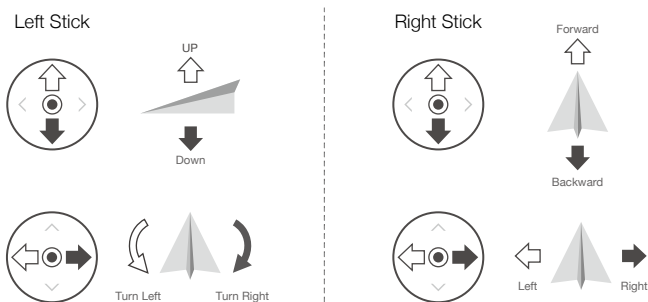

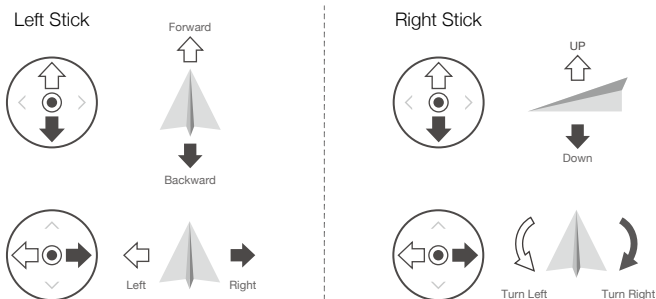

Mode 2

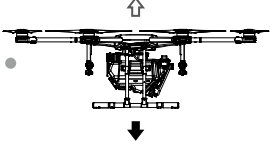

Mode 3

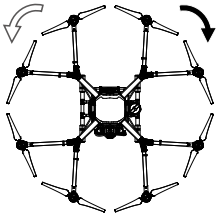

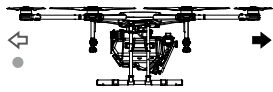
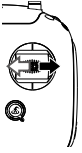

For example, the following description uses Mode 2:

Remote Controller (Mode 2)	Aircraft (● Indicates nose direction)	Remarks
		<p>Throttle Stick: Vertical movement of the left stick controls the aircraft's elevation. Push up to ascend and push down to descend. Use the left stick to take off when the motors are spinning at idle speed. The aircraft will hover in place if the stick is in the center position. The farther the stick is pushed away from the center position, the faster the aircraft will change elevation.</p>
		<p>Yaw Stick: Horizontal movement of the left stick controls the aircraft's heading. Push left to rotate the aircraft counterclockwise and push right to rotate clockwise. The aircraft will hover in place if the stick is in the center position. The farther the stick is pushed away from the center position, the faster the aircraft will rotate.</p>
		<p>Pitch Stick: Vertical movement of the right stick controls the aircraft's pitch. Push up to fly forwards and press down to fly backwards. The aircraft will hover in place if the stick is in the center position. Push the stick farther for a larger pitch angle and faster flight.</p>
		<p>Roll Stick: Horizontal movement of the right stick controls the aircraft's roll. Push the stick left to fly left and right to fly right. The aircraft will hover in place if the stick is in the central position. Push the stick farther for a larger roll angle and faster flight.</p>

Flight Mode Switch

Toggle the Flight Mode switch on the remote controller to one of the three following modes:

Figure	Flight Mode
	P-mode (Positioning)
	A-mode (Attitude)
	F-mode (Function)

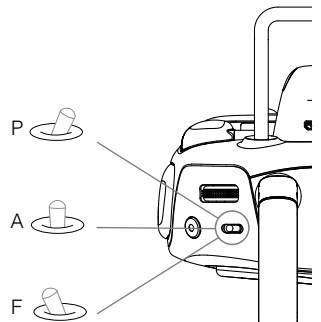

P-mode (Positioning): The aircraft uses GNSS for positioning. In P-mode, users can start the motors when the GNSS signal is strong.

A-mode (Attitude): GNSS is not used for positioning, and aircraft can only maintain altitude using the barometer. Aircraft can still record its position and return to the Home Point if a GNSS signal is present.

F-mode (Function): Plan tasks in advance in the DJI MG app. The aircraft will automatically perform the selected task after entering F-mode.

The aircraft will always fly in F-mode by default after powering on regardless of the Flight Mode switch position. If the Flight Mode switch is at P or A when powered off, set the switch to any other position and then to P or A after powering on the aircraft to use P-mode or A-mode.

Atti Mode Warning

The aircraft will enter A-mode in the following two instances:

Passive: When there is weak GPS signal or when the compass experiences interference.

Active: Users toggle the flight mode switch to A-mode.

In A-mode, some advanced features are disabled. Therefore, the aircraft cannot position in this mode and is easily affected by its surroundings, which may result in horizontal shifting. Use the remote controller to position the aircraft.

Maneuvering the aircraft in A-mode can be difficult. Before switching the aircraft into A-mode, make sure you are comfortable flying in this mode. DO NOT fly the aircraft too far away as you might lose control and cause a potential hazard.

Avoid flying in areas where GPS signal is weak, or in confined spaces. The aircraft will otherwise be forced to enter A-mode, leading to potential flight hazards, please land it in a safe place as soon as possible.

Operation Mode Switch

In P-mode, set the Operation Mode switch on the remote controller to one of the three modes.



Smart Operation Mode (S)



Manual Operation Mode (M)



Manual Plus Operation Mode (M+)

- 1. Smart operation mode (S):** When the aircraft is in P-mode and the GNSS signal is strong, set the switch to this mode after recording Points A and B. The aircraft will fly and spray liquid along the specified route. The DJI MG app will display "A-B Route."
- 2. Manual operation mode (M):** Users can control all the movements of the aircraft and spray liquid via the Spray, C3, and C4 buttons. The DJI MG app will display "Manual Route."
- 3. Manual Plus operation mode (M+):** Users can control the movement of the aircraft, but flying speed is restricted and heading is locked. Press the C1 or C2 buttons and the aircraft will fly one line spacing to the left/right. The DJI MG app will display "M+ Route."

Controlling the Spraying System

Complete a task remotely via the Spray Rate or Settings dials, or the Spray, A/B, and C1/C2/C3/C4 buttons.

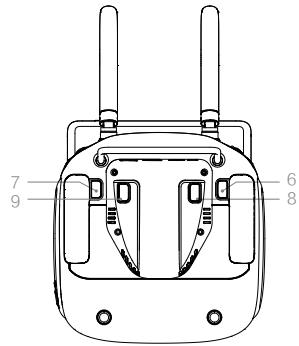
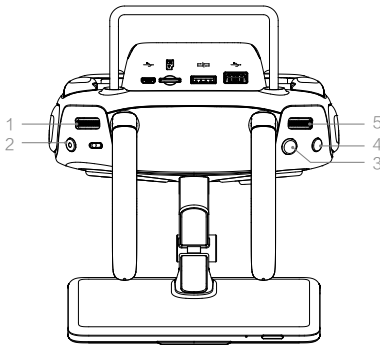

1. Spray Rate Dial

In Manual or Manual Plus operation mode, turn left to reduce and right to increase the spray rate¹. The DJI MG app will indicate the current spray rate.

2. Spray Button

In Manual operation mode, press to start or stop spraying.

3. A Button

Press to record Point A of the Smart operation route.

4. B Button

Press to record Point B after recording Point A.

5. Settings Dial

In Smart operation mode or F-mode, turn to adjust work efficiency, including flying speed and spray rate.

6. C1 Button

In Smart operation mode, press to choose operation route L, after recording Point A and B.

In Manual Plus operation mode, press to fly the aircraft one line spacing to the left.

During Field Plan² press to start or end obstacle measurement if you want to mark an obstacle in the operating area.

7. C2 Button

In Smart operation mode, press to choose operation route R, after recording Point A and B.

In Manual Plus operation mode, press to fly the aircraft one line spacing to the right.

During Field Plan, walk along the operating area or obstacle and press to add a waypoint.

In Smart operation mode, when the aircraft is hovering at a turning point, press the C1 and C2 buttons simultaneously to fly to the next turning point and hover.

Press and hold the C1 and C2 buttons simultaneously for 2 to 4 seconds and the remote controller will beep to enter or quit Continuous Smart operation mode. Refer to [Smart Operation Mode \(p. 32\)](#) for more details.

¹ Spray rate may vary according to the nozzle model and viscosity of the liquid. When using water, four XR11001 nozzles spray at a minimum rate of 1.2 L/min, and maximum 1.8 L/min.

² When the remote controller is not connected to the aircraft, "Field Plan" will display on the DJI MG main interface. Tap the C1 button to enter Operation View for route planning. Refer to [Intelligent Operation Planning System \(p. 30\)](#) for details.

8. C3 Button

In Manual Mode, press to spray liquid with the two front sprinklers only.
 During Field Plan, walk to the desired calibration point and press to add the point.

9. C4 Button

In Manual mode, press to spray liquid with the two back sprinklers only.

The table below is a summary for how to control the spraying system via the remote controller in different modes.

Mode	Spray Rate Dial	Spray Button	Settings Dial	C1 Button	C2 Button	C3 Button	C4 Button
Smart operation mode	/	/	Adjust work efficiency	Press simultaneously to fly to the next turning point and hover. Press and hold simultaneously for 2-4 seconds and the remote controller will beep to enter or quit Continuous Smart operation mode.		/	/
Manual operation mode	Adjust spray rate	Start or stop spraying	/	Choose operation route L for Smart Operation mode	Choose operation route R for Smart Operation mode	Spray with only the two front sprinklers	Spray with only the two back sprinklers
Manual Plus operation mode	Adjust maximum spray rate	/	Adjust maximum flying speed	Fly the aircraft one line spacing to the left	Fly the aircraft one line spacing to the right	/	/
F-mode	/	/	Adjust work efficiency	/	/	/	/
Field Plan	/	/	/	Start or end obstacle measurement	Add a waypoint.	Add the calibration point	/

RTH Button

Press and hold the RTH button to bring the aircraft back to the last recorded Home Point. The LED around the RTH Button will blink white during RTH procedure. During ascent and descent, users can control all aircraft movement. Users can control aircraft heading while it flies to the Home Point. Press this button again to cancel RTH and regain control of the aircraft.

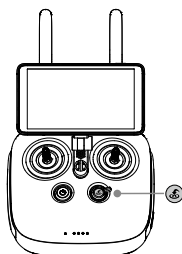

Optimal Transmission Range

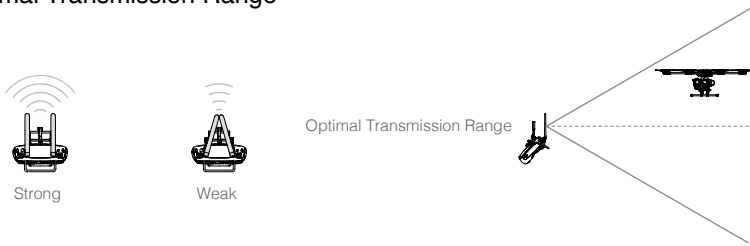

Signal transmission between the aircraft and remote controller performs best when the aircraft is within optimal transmission range. Unfold the antennas on the remote controller to optimize transmission range. Ideally, the flat surface of the antennas should be facing the aircraft. If the signal is weak, fly the aircraft closer to you.

Remote Controller LEDs

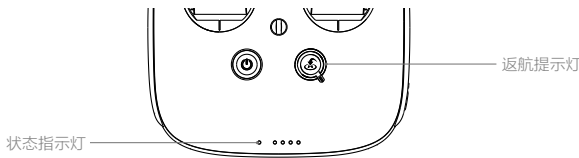

The Status LED indicates the connection status between the remote controller and the aircraft. The RTH Status LED indicates the Return to Home status of the aircraft. See the table below for details on these indicators:

Status LED	Sound	Remote Controller Status
— Solid Red	♪ chime	The remote controller is not connected to the aircraft.
— Solid Green	♪ chime	The remote controller is connected to the aircraft.
..... Blinks Red	Repeating slow beep	Remote controller error.
RTH Status LED	Sound	Aircraft Status
— Solid White	♪ chime	Return to Home procedure is initiated.
..... Blinking white	Repeating single beep	Sending Return to Home command to the aircraft.
..... Blinking white	Repeating double beep	The aircraft is returning to the Home Point.

Linking the Remote Controller

The remote controller is linked to your aircraft by default. Linking is only required when using a new remote controller for the first time.

Before linking, go to Operation View in the DJI MG app > ●●● > 📱 > Connected DJI Device Type. Make sure to choose "MG-1S". Then follow these steps to link a new remote controller:

1. There are two methods to enter linking status:

Method 1: Via the DJI MG app

- a. Power on the remote controller and open the DJI MG app. Power on the aircraft.
- b. Tap Field Plan to enter Operation View > ●●● > 📱, then tap Linking RC.
- c. A window will indicate that the remote controller has initiated linking.

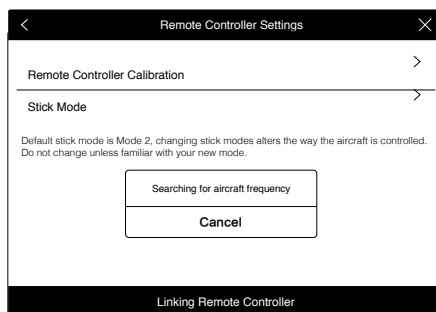

Method 2: Via the buttons on the remote controller

- a. Power on the remote controller, and then the aircraft.
 - b. Press and hold the C1, C2, and Spray buttons simultaneously until the remote controller beeps once, and then twice. While pressing and holding the C1, C2, and Spray buttons, press the Settings dial.
2. The Status LED blinks blue and the remote controller sounds double beep repeatedly, indicating that the remote controller is ready for linking.
 3. Press and hold the Link button on the aircraft for 3 seconds or until the Link LED blinks red and green alternately. Release the button and wait for a few seconds.
 4. The Status and Link LED will glow solid green if linking is successful.
If the Link LED does not glow solid green, linking failure occurred. Enter linking status again and retry.

The DJI MG App

The DJI MG app is designed for agricultural applications and is able to display the system status and configure various settings. After planning a task via the app's intelligent operation planning system, the aircraft can operate automatically following the produced flight route when in F-mode.

Main Interface



1. Field Plan / Start Task

Field Plan: When the aircraft is not connected, tap to enter Operation View for task planning.

Start: After the aircraft is connected, tap to enter Operation View to perform planned tasks or view the aircraft status and configure settings.

2. Aircraft Connection Status

O: Shows whether the aircraft or D-RTK Handheld Mapper is connected to the remote controller.

3. Task Management

📄: Manage your tasks here, including uploading local tasks to the DJI Agriculture Management Platform and downloading tasks from it.

4. User Info

👤: View user information of the account logged in.

5. Aircraft Info

✂️: View the information of the connected aircraft and manuals.

6. General Settings

⚙️: Tap for settings such as units of measurement, offline map, cellular data statistics, and network diagnosis.

Operation View

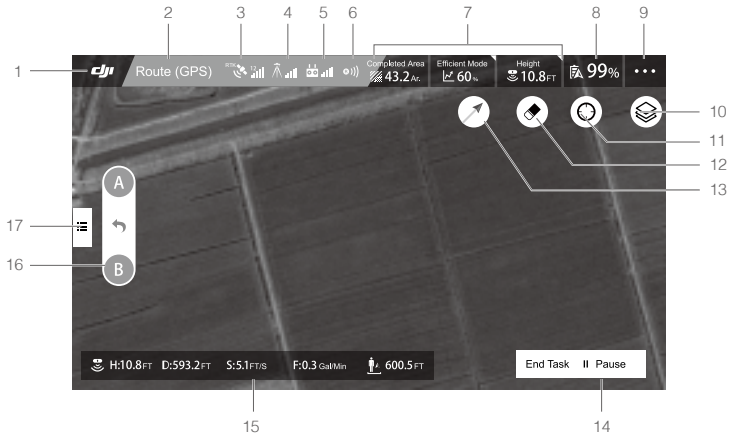

1. Main Interface

DJI : Tap this icon to return to the main interface.

2. System Status

Route (GPS) : Indicates current flight modes, operation modes, and warning messages.

3. GNSS Status

RTK : Shows the current GNSS signal strength and number of satellites connected. When using RTK data, "RTK" will appear in the upper left corner.

4. RTK Status

Icons displayed when using RTK data.

RTK : Displays RTK signal strength when using the D-RTK Base Station.

RTK : Indicates that the connection with the D-RTK Base Station is abnormal. Refer to the prompts in the app.

5. Remote Controller Signal

RC : Shows the signal strength of the remote controller.

6. Obstacle Avoidance Radar Status

AR : Shows the working status of the Obstacle Avoidance Radar.

7. Operation Parameters

Shows parameters of current spraying operation. The display will vary according to flight and operation mode.

PA : Plan Area — Shows the Plan Area value when planning tasks via the intelligent operation planning system.

CA : Completed Area — Shows the completed area value in Route or A-B Route mode.

WTE : Work Type and Efficiency — Shows work type and efficiency settings in Route or A-B Route mode. Tap to set Pesticide Usage for Spray, choose Efficient or Intensive mode, and use the slider to adjust work efficiency. You can also adjust work efficiency via the Settings dial on the remote controller.

 : Height — When Radar Terrain Follow System is enabled, shows the preset height between the aircraft and the object under it. Appears in all modes except Manual operation mode. Tap to adjust the height.

 : Spacing Line — shows the preset distance when flying left or right in A-B Route or M+ mode. Tap to adjust the value.

 : Flow Rate — In M+ mode, shows the current pesticide flow rate. Tap to adjust the value. You can also adjust flow rate via the Spray Rate dial on the remote controller.

 : Work Speed — Shows the maximum flying speed in M+ mode. Tap to adjust the value.

8. Battery Level

 99% : Shows the current battery level. Tap to set the Low Battery Warning threshold and view battery information.

9. More Settings

••• : Tap to enter the extended menu to view and adjust the parameters of all other settings.

 : Aircraft Settings — Includes safety distance, ascend without pesticide, advanced settings, etc.

 : MC Parameter Settings — Includes Home Point settings, Return to Home altitude, maximum altitude, distance limit, RC signal lost, advanced settings, etc.

 : RC Settings — Includes Connect DJI Device Type, RC calibration, exchange functions for remote controller buttonsstick mode, and linking RC.

RTK : RTK Settings — Includes RTK satellite status, and RTK module switch.

 : Aircraft Battery — Includes Low Battery Warning, battery information, etc.

••• : General Settings — Includes map settings, flight route display, etc.

10. Map Mode

 : Tap to switch among Standard, Satellite, or Night modes.

11. Location

 : Tap to center the map around the aircraft's location or the latest recorded Home Point.

12. Clear Screen

 : Tap to clear the flight path currently shown on the map.

13. Location Follow

 : Tap to center the map around the aircraft's location at all times, following its location update.

14. Task Control Buttons

Buttons to control during different task types, including measure a work area, use, start, pause, or end a task, etc.

15. Flight Parameters

 H: When the Radar Terrain Follow System is enabled, shows the preset height between the aircraft and the object underneath it.



D: Horizontal distance from the aircraft to the Home Point.

S: Flying speed.

F: Pesticide flow rate.

 : The horizontal distance between the aircraft and the operator.

16. Point A / B

 /  : Tap to record Point A or B. The color of the icon will change from grey to purple to indicate successful recording.

 : Tap to clear the recorded Point A or B.

17. Task List

 : In Route mode, tap to list all the planned route tasks. Choose the desired task from the list.

Intelligent Operation Planning System

After the operation area and obstacles have been measured, and calibration points have been added by using the remote controller or DJI D-RTK Handheld Mapper (for MG-1S RTK only), the DJI MG app uses a built-in Intelligent Operation Planning System to produce a flight route based on the user's input. Users can edit the planned task for flight path adjustment in the app. In F-mode, the aircraft can operate automatically, following the generated flight route. Refer to the instructions below or watch the video tutorial on the official DJI website to use the Intelligent Operation Planning System and perform tasks. (<http://www.dji.com/mg-1s/info#video>).

 Ensure that the aircraft is powered off when planning your flight route.

Field Planning

Users can plan the field by using the remote controller or DJI D-RTK Handheld Mapper (for MG-1S RTK only).

Using the Remote Controller

1. Power on the remote controller and enter the DJI MG app.
2. Tap Field Plan in the lower left corner of the screen to enter Operation View.
3. Wait until GNSS signal is strong. Positioning accuracy will be about +/-2 meters.
4. Tap Start Measuring in the lower right corner of the screen. Walk along the edge of the target field. Tap "Add Waypoint C2" or press Button C2 on the back of the remote controller at each corner of the field.
5. Mark any obstacles:
Use two methods below to mark obstacles if there is any in the target field.
 - ① Tap Start Obstacle Measurement C1 onscreen or press the C1 button on the back of the remote controller, walk around the obstacle, and then tap End Obstacle Measurement C1 onscreen or press the C1 button again.
 - ② Tap Start Obstacle Measurement C1 onscreen or press the C1 button on the back of the remote controller, walk around the obstacle, and tap Add Waypoint C2 onscreen or press the C2 button to add waypoints. Tap End Obstacle Measurement C1 onscreen or press the C1 button when finished.
6. Continue measuring the field by walking along the edge and adding waypoints at each corner of the field. Tap End Measurement when the field has been measured and all obstacles have been marked. The DJI MG app will produce a flight route according to the field's perimeter and obstacles.
7. Add calibration point(s): Walk to the location of each calibration point. Tap Add Calibration Point C3 onscreen or press the C3 button on the back of the remote controller.
The calibration points are used to offset the bias of the flight route caused by the positioning difference between the remote controller and aircraft. Choose at least one existing landmark as the fixed reference point(s) for calibration when executing the same task. If none are available, use an easily identifiable object, such as a metal stake.

Using the DJI D-RTK Handheld Mapper (for MG-1S RTK only)

Refer to the D-RTK Handheld Mapper User Guide to complete field planning, then choose the corresponding task in the DJI MG app.

Task Editing

Tap any blank space onscreen to enter Edit Status.

1. Edit Waypoints

Move: Drag the waypoint to move.



Fine Tuning: Tap the waypoint to show Fine Tuning buttons. Tap to adjust.

Delete: Tap twice to delete a waypoint.

2. Adjust Route

Route Direction: Tap and drag the  icon near the route to adjust the flight direction of the produced route.

Line Spacing: Tap the  icon at the top of the screen to adjust the line spacing between two neighboring lines.

Safety Distance: Tap the  icon on top of the screen, and then adjust the safety distance between the route and the edge of the field or obstacle in  Aircraft Settings.

3. Edit Obstacles

Tap and hold the marked obstacle or the position that needs to mark an obstacle on the screen to choose the shape and size of the obstacle in the menu.

Tap the obstacle on the screen which has waypoints added, then follow the Edit Waypoints instructions to edit the added waypoints for complete obstacle information.



If a route error appears in the app after importing data from the mapper to the remote controller, it is because of the short distance between two obstacles. Edit the obstacles in the app to clear this error.

4. Tap “Save”, and then name the task, choose crop, and configure other parameters.

Starting a Task

1. Place the aircraft at one of the previously set calibration points and then power it on.

2. Toggle the flight mode switch to F-mode. Power on the remote controller and go to Operation View in the DJI MG app >  >  > Connected DJI Device Type. Make sure to choose “MG-1S”.

3. Tap Task List onscreen, choose a previously saved task, and then tap Use Task.

4. Tap Rectify Offset and then Rectify Aircraft Position, or adjust the route position via the Fine Tuning buttons and then tap OK.

5. Tap Start, and then set work type.

6. Takeoff and start the task.

① If you fly to the targeted height, a Slide to Execute prompt will appear onscreen. Slide to start spraying.

② If the aircraft is on the ground, a Slide to Takeoff prompt will appear onscreen. Slide to takeoff and start spraying.



- Be sure to takeoff in open areas.
- The task will be automatically cancelled if the motors are started before beginning the task. You will need to recall the task in the task list.
- Once started, the aircraft will fly to the starting point of the route and lock its heading in the direction of the first turning point for the duration of the flight path.
- During the task, the aircraft automatically sprays liquid while flying forwards or backwards, and it doesn't spray liquid while flying left and right. Users can adjust work efficiency (flying speed and spray rate included) and height above the crops in the DJI MG app.
- The aircraft will hover at the ending point of the flight route after the task is completed.

Aircraft

Profile

The MG-1S / MG-1S RTK uses DJI's dedicated A3 Flight Controller to provide three flight modes and operation modes for various applications. A Radar Terrain Follow System guides the aircraft to maintain a constant distance above crops in each flight or operation mode. Functions such as operation resumption, system data protection, empty tank warning, Return to Home (RTH) and low battery level warning are also available. The MG-1S RTK has a built-in DJI Onboard D-RTK, providing more accurate data for centimeter-level positioning to ensure more precise and stable flight when used with the DJI D-RTK Base Station.

- ⚠️ • When using your MG-1S / MG-1S RTK for the first time, activate it in the DJI MG app. Your DJI account and internet connection are required.
- Effective use of pesticides relies on pesticide density, spray rate, spray distance, aircraft speed, wind speed and wind direction. Consider all factors when using pesticides.
- Always fly at an appropriate height above crops to avoid damage.

Operation Modes

When the Flight Mode Switch is set to P, the MG-1S / MG-1S RTK provides Smart, Manual, and Manual Plus operation modes. Switch to one of the three modes via the Operation Mode switch on the remote controller.

Smart Operation Mode

In Smart operation mode, the aircraft will travel along a pre-planned route. Operation resumption, data protection, and the Radar Terrain Follow System are available in this mode. Use the Settings dial on the remote controller or app to adjust work efficiency (including flying speed and spray rates). Smart operation mode is recommended for large, rectangular spray areas.

Operation Route

The aircraft will travel along a pre-designated square zig-zag route after recording turning points A and B. Under optimal working conditions, the aircraft maintains distance from the vegetation. The length of the dotted lines, called Line Spacing, can be adjusted in the DJI MG app.

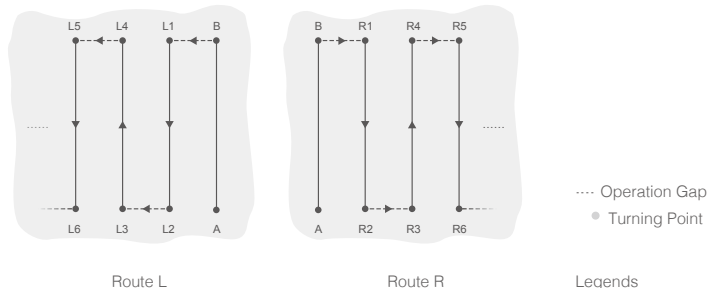

Operation Procedure

-  • Maintain line of sight of the aircraft at all times.
- Set the Flight Mode switch to P when GNSS signal is strong. Otherwise, Smart operation mode may be unreliable.

 Always inspect operating environments before flying.

Set the remote controller's Flight Mode Switch to P when a strong GNSS signal is present. In addition, set the Operation Mode switch to M.

1. Record Points A and B in Order

Users cannot set the Operation Mode switch to Smart operation mode until they have recorded points A and B.

Fly the aircraft to the starting point, depicted as Point A/B, hover, and then press Button A/B on the remote controller or tap Point A/B onscreen. The icon for Point A/B will change from gray to purple and the Aircraft Status Indicator will blink red/green after recording the starting points.

-  • Points A and B cannot be recorded if the spray tank is empty.
- Update Point B by flying the aircraft to a new position to record. Note that if you update Point A, you must also update Point B.
- It is recommended to keep the direction of Point A to B parallel to one side of the rectangular spray area for optimal effect.

-  • After recording Point A, there will be a menu prompt for work type settings. Set the amount of pesticide per acre and work type. Use the slider to adjust work efficiency. During the task, tap the icon at the top of the screen to adjust parameters. You can also adjust work efficiency via the Settings dial on the remote controller.
- The DJI MG app will display an icon of line spacing. Tap to adjust the value. The line spacing cannot be adjusted during operation. Switch to Manual or Manual Plus operation mode to adjust the value, then go back to Smart operation mode.

2. Select the Route

Press the C1 or C2 buttons on the remote controller to select the operating pattern. Press C1 for Route L and C2 for Route R. The default route pattern is Route R if no selection has been made.

-  Users can select the route in Manual operation mode only. If the aircraft is in Smart operation mode, select the route after switching to Manual operation mode.

3. Configuring Aircraft Altitude

Configure the desired altitude in the DJI MG app and adjust the aircraft altitude to a value within the working range of the Radar Terrain Follow System (1.5-3.5 m) by using the throttle stick before entering Smart operation mode. The Radar Terrain Follow System will start working automatically and maintain the spraying distance between aircraft and vegetation. Refer to the Radar Terrain Follow System for details.

4. Using Smart Operation Mode

Set the remote controller's Flight Mode switch to P and ensure that a strong GNSS signal is present, then set the Operation mode switch to S to enable Smart operation mode.



- ☀️ • If, after recording Points A and B, you fly the aircraft more than five meters away from Point B and the Operation Mode switch is not set to S, Resume will appear on the lower right corner of the screen when you enter Smart operation mode. Tap Resume, and the aircraft will automatically fly to Point B to re-enter Smart operation mode.
 - When using the control sticks to control the aircraft in Smart operation mode, the aircraft will automatically switch to Manual operation mode, complete corresponding flight behavior, and then hover. To resume the task, set the Operation Mode switch to S, then tap Resume onscreen. The aircraft will return to Smart operation mode, then resume flying along the operation route. Refer to [Operation Resumption \(p. 35\)](#) for details.
-

5. Starting the Operation

- Press the remote controller's C1 and C2 buttons simultaneously. The aircraft will align with the line between Points A and B with its heading pointing toward Point B. Fly laterally from Point B to L1/R1, then hover at Point L1/R1 and wait for further instructions.
 - Repeat the previous step and the aircraft will fly to the next turning point along Route L/R and hover.
 - Enable Continuous Smart operation mode by pressing and holding the C1 and C2 buttons simultaneously for 2-4 seconds when the aircraft is hovering at any given turning point. The Aircraft Status Indicator will turn solid purple for one second. The aircraft will then fly along Route L/R continuously. The DJI MG app will display the A-B Route.
 - To exit Continuous Smart operation mode, press and hold the C1 and C2 buttons simultaneously for 2-4 seconds. The aircraft will fly to the next turning point and hover.
-

- ⚠️ • The nose of the aircraft will always point from Point A to Point B regardless of flight direction. Heading cannot be adjusted.
 - You will only be able to press and hold the C1 and C2 buttons for steps a to c when the aircraft is hovering at a turning point.
 - If GNSS signal is weak during operation, the aircraft will automatically switch to Attitude mode. Exit Smart operation mode and control the aircraft manually. When the aircraft regains a strong GNSS signal, it will automatically fly to the next turning point.
 - If you press the A or B buttons during operation, the data for Points A and B of the current route will be erased and the aircraft will hover in place.
-

- ☀️ • The line spacing can be customized from 3-10 m in DJI MG. It is set to a length of 5 m by default.
 - Even though the heading of the aircraft cannot be adjusted, use the control sticks to avoid obstacles. Refer to [Manual Obstacle Avoidance \(p. 36\)](#) for details.
 - The aircraft automatically sprays liquid when flying forwards or backwards, and does not spray when flying left or right or when hovering.
-

Manual Operation Mode

Set the Operation Mode switch to M to enter Manual operation mode. You can control all the movements of the aircraft, spray liquid via the remote controller's Spray button, and adjust the spray rate via the dial. Refer to [Controlling the Spraying System \(p. 22\)](#) for details. Manual operation mode is ideal when the operating area is small.

Manual Plus Operation Mode

Set the Operation Mode switch to M+ to enter Manual Plus operation mode. The aircraft's Maximum flying speed is 7 m/s (customizable in the DJI MG app), the heading is locked, and all other

movement can be manually controlled in this mode. Press the C1 or C2 buttons on the remote controller to steer the aircraft left or right. The aircraft sprays liquid automatically when flying forward or backward, and does not spray when flying left and right. Manual Plus operation is ideal for irregularly-shaped operating areas.

1. Elevate the aircraft to the desired altitude within the working range of the Radar Terrain Follow System (1.5-3.5 m) before entering Manual Plus operation mode. The Radar Terrain Follow System starts working automatically by maintaining the spraying distance between the aircraft and the vegetation below. Refer to Radar Terrain Follow System for details.
2. Ensure that the aircraft is in P-mode and the GNSS signal is strong (≥ 10 connected satellites). Then set the Operation Mode switch to M+ to activate Manual Plus operation mode.



- If the line spacing has been adjusted in Manual Plus operation mode, the value of Smart operation mode will apply the adjustment.
- Spray rate will be adjusted automatically according to the flying speed.
- Maximum spray rate, maximum flying speed, line spacing, and height above the crop can be adjusted in the DJI MG app.
- The aircraft cannot be controlled when using the C1 or C2 buttons to steer the aircraft to the left or right. Switch to Manual operation mode in case of emergency, and the aircraft will stop flying.

Operation Resumption

When exiting Smart Operation Mode or a route task, the aircraft will record a breakpoint. The Operation Resumption function allows you to pause an operation temporarily (e.g., to refill the spray, change battery, and avoid obstacles manually) and then resume operation at the breakpoint.

Instructions

Recording a Breakpoint

Exit Smart operation mode or F-mode through one of the following methods and the aircraft will record its location as a breakpoint if GNSS signal is strong:

1. Set the Operation Mode switch out of Smart operation mode.
2. Initialize the RTH procedure.
3. Set the Flight Mode switch out of P-mode or F-mode.
4. Push the Pitch or Roll stick in any direction on the remote controller.



- Ensure that GNSS signal is strong when using the Operation Resumption function. Otherwise, the aircraft cannot record and return to the break point.
- The breakpoint will be updated as long as you set the Operation Mode switch to any other mode besides Smart operation mode, the Flight Mode switch to any other mode besides P-mode or F-mode, and you trigger RTH during Smart operation mode or F-mode.

Resume Operation

1. Exit Smart operation mode or F-mode through one of the four above methods. The current location of the aircraft will be recorded as the breakpoint.
2. Fly the aircraft to a safe location before resuming operation. If the Radar Terrain Follow System is enabled, adjust the spraying distance between the aircraft and the vegetation to be within working range (1.5-3.5 m).

- 3. Resume
 - a. Back to the following modes:
 - Smart operation mode — Set the Flight Mode switch to P and the Operation Mode switch to S.
 - F-mode — Set the Flight Mode switch to F.
 - b. Tap Resume on the lower right corner of the DJI MG app.
- 4. Return Route

If the aircraft is in the operating area, there will be prompt in the DJI MG app. Users can select from returning to the breakpoint or the operating route along a path vertical to the operating route. If the aircraft is out of the operating area, it will return straight to the breakpoint and resume operation.
- 5. If obstacle avoidance is required during the return procedure, users can control the aircraft forwards, backwards, left, and right. Refer to Manual Obstacle Avoidance for details.

Typical Applications

In Smart operation mode or F-mode, users can control the aircraft forward, backward, left, and right, avoiding obstacles along the operation route, or in an emergency (e.g., abnormal aircraft behavior). The following instructions describe how to avoid obstacles manually:

Manual Obstacle Avoidance

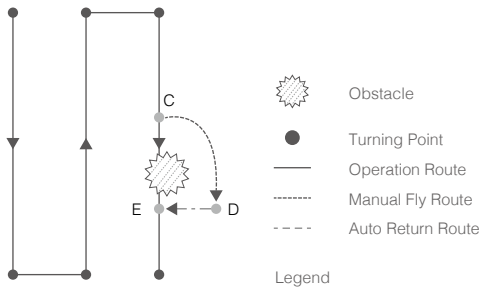

- 1. Exit Smart Operation Mode or F-mode

In the two modes, when using the control sticks to control the aircraft forward, backward, left or right (i.e., push the pitch or roll stick), the aircraft will automatically exit the current mode, pause the task and record the current position as a breakpoint (Point C), then complete the corresponding flight behavior and hover.

⚠ When pushing the control sticks to exit Smart Operation mode, the aircraft will need a braking distance. Ensure that there is a safe distance between the aircraft and any obstacles.

- 2. Avoid an Obstacle

After switching to Manual operation mode, users can control the aircraft to avoid the obstacle from Point C to D.
- 3. Resume Operation

Enter the corresponding mode, and then tap Resume in the DJI MG app. If the aircraft is in the operating area, there will be a prompt in the DJI MG app. Select Fly to Project Point. If the aircraft is out of the operating area, it will return straight to the breakpoint and resume the operation.

-
- ⚠ • To avoid risk, ensure that the aircraft has completely avoided the obstacle before resuming operation.
 - In the event of an emergency, ensure that the aircraft is in normal status and then fly the aircraft manually to a safe area to resume operation.
-
- ☀ Repeat the instructions above to exit and resume operation in the event of an emergency (i.e., whenever obstacle avoidance is required) during the return procedure.
-

System Data Protection

The System Data Protection feature enables the aircraft to retain vital system data (e.g., Point A, Point B, breakpoint) for about 30 seconds after the aircraft is powered off. Retaining vital system data allows the aircraft to resume operation after a short, temporary pause. Follow the instructions below to use this feature:

1. Exit Smart operation mode or F-mode. The current location of the aircraft will be recorded as the breakpoint.
2. Land the aircraft and stop the motors.
3. Once the aircraft is powered off, System Data Protection is automatically triggered, indicated by The Aircraft Status Indicator glowing solid green.
4. Replace the battery within the 30-second window
5. Restart the aircraft and enter Manual operation mode.
6. Ensure that the GNSS signal is strong, then start the motors.
7. Follow the instructions in Operation Resumption to resume the operation.

-
- ⚠ System data can only be retained for 30 seconds. DO NOT power off the aircraft for more than 30 seconds if you want to resume operation, as system data will be lost.
-

Radar Terrain Follow System

Profile

The Radar Terrain Follow System consists of forward, rear, and downward radar modules that use microwave technology to follow the terrain. In an optimal operating environment, the system can predict the distance between the aircraft and the crop or other surface in forward, rear, and downward directions to fly at a constant distance to ensure even spraying. The function is enabled by default, and can be disabled in the DJI MG app. When enabled, the aircraft will fly above the crop at a constant spraying distance in Smart and Manual Plus operation modes and F-mode. In Manual operation mode, the system can also measure the spraying distance above the vegetation or other surface, but the aircraft will not be able to fly at a constant spraying distance.

Using the Radar Terrain Follow System

1. Ensure that you have enabled the Radar Terrain Follow System in the DJI MG app.
2. Configure the desired spraying distance (1.5-3.5 m).
3. If using Smart or Manual Plus operation mode, ensure that you have set the Flight Mode switch to P and the Operation Mode switch to M. If using F-mode, ensure that the Flight Mode switch is set to F. Fly the aircraft above the vegetation and adjust the distance between the aircraft and the vegetation to a value within the working range (1.5-3.5 m).

4. Set the Flight Mode and Operation Mode switches to the desired position to enter the corresponding mode. If the operating environment is ideal, the aircraft will fly above the vegetation at the preset height.

-  • The Radar Terrain Follow System will only maintain a fixed distance from vegetation within its working range (1.5-3.5 m).
- Observe the aircraft's distance from the vegetation at all times.
- Operate with extra caution when flying over inclined surfaces (depending on aircraft speed). Recommended maximum inclination at different speeds: 15° at 1 m/s, 6° at 3 m/s and 3° at 5 m/s.
- Obey local radio transmission laws and regulations.

Radar Status Display

The Radar Status Indicator shows the current status of the Radar Terrain Follow System. See the table below:

Blinking Pattern	Description
Solid (Forward Radar: Blue, Rear Radar: Green, Downward Radar: Yellow)	Warming up
Blinking (Forward Radar: Blue, Rear Radar: Green, Downward Radar: Yellow)	Working
Off	Disconnected: check the cable connection

Radar Status will be shown in the DJI MG app. Pay attention to the prompt messages at all times and fix any issues that may occur.

Empty Tank Warning



Profile

The DJI MG app will indicate when the spray tank is empty. The aircraft will move according to the current operation or flight mode and will ascend 3 m* and hover (Smart or Manual Plus operation mode), or hover in place (Manual operation mode or F-mode).



* The feature for hovering at 3 m must be enabled in the DJI MG app. If not enabled, the aircraft will hover in place at its current altitude and position until you manually control it.

Using the Empty Tank Warning

1. In Manual operation mode or F-mode, press the Spray button on the remote controller when the empty tank warning is triggered to turn off the sprinklers. Failure to do so may cause the tank motor pump to idle, causing damage. In Smart or Manual Plus operation mode, the sprinklers will automatically turn off.
2. Ensure that the aircraft is in Manual operation mode, land, and stop the motors. Refill the spray tank and tighten the lid.
3. Press the Spray button on the remote controller to discharge the remaining air in the pump until the empty tank warning in the DJI MG app disappears. Press the Spray button again to stop discharging.
4. Ensure the aircraft is in Manual operation mode, and then take off.
5. Elevate the aircraft to a desired altitude in F-mode, Smart, or Manual Plus operation mode. Adjust the spraying distance between the aircraft and the vegetation to be within the working range (1.5-3.5 m). Refer to the [Radar Terrain Follow System](#) (p. 37) for details. Then enter the desired mode.

-  The remaining pesticide for empty tank warning can be set in the DJI MG app. Enter Operation View >  > Remaining Pesticide Status.

Return to Home (RTH)

-  **Home Point:** The default Home Point is the first location where your aircraft received strong GNSS signals  (the white GNSS icon is followed by at least four white bars). The Aircraft Status Indicator will blink several times after the Home Point has been recorded.
- RTH:** The Return to Home (RTH) function brings the aircraft back to the last recorded Home Point.

-  When using System Data Protection, the Home Point will not be updated if you restart the aircraft after changing the battery.

There are two events that will trigger RTH procedure: Smart RTH and Failsafe RTH.

Smart RTH

Press and hold the RTH button on the remote controller when GNSS is available to enable Smart RTH. Both Smart and Failsafe RTH use the same RTH procedure. With Smart RTH, you may control the aircraft's speed and altitude to avoid collisions when returning to the Home Point. The Aircraft Status Indicator will show the current flight mode during RTH. Press the Smart RTH button once to exit Smart RTH and regain control of the aircraft.

Failsafe RTH

-  Failsafe RTH must be enabled in the DJI MG app. If Failsafe RTH is not enabled, the aircraft will hover in place when the remote controller signal is lost.

Failsafe RTH activates automatically if the remote controller signal is lost for more than three seconds, provided that the Home Point has been successfully recorded, the GNSS signal is strong (white GNSS icon), and the compass is working normally. Users can interrupt the Return to Home procedure and regain control of the aircraft if the remote controller signal is recovered. Press the RTH button on the remote controller once to cancel RTH.

RTH Illustrator

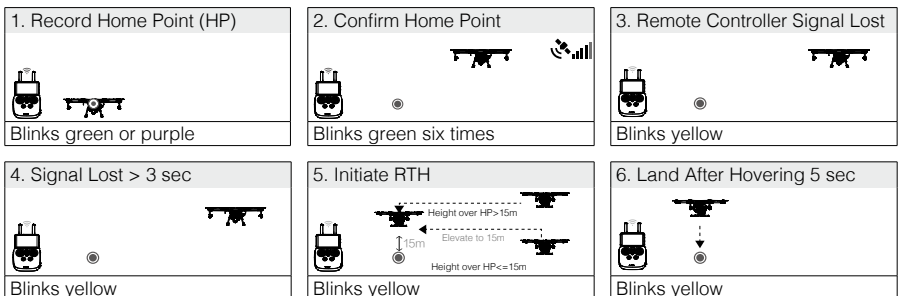





Updating the Home Point

You can update the Home Point in the DJI MG app during flight. There are two options for setting the Home Point:







1. Set the aircraft's current coordinates as the Home Point.
2. Set the remote controller's current coordinates as the Home Point.

-  Ensure the space above the remote controller's GNSS module (located beneath the DJI logo) is not obstructed and that there are no tall buildings around when updating the Home Point.

Follow the instructions below to update the Home Point:

1. Go to DJI MG > Operation View.
2. Tap ●●● > , select  in Home Point settings to set the remote controller's current coordinates as the Home Point.
3. Tap ●●● > , select  in Home Point settings to set the aircraft's current coordinates as the Home Point.
4. The Aircraft Status Indicator will blink green to indicate that the new Home Point has successfully been set.

RTH Safety Notices

	<p>The aircraft cannot avoid obstacles during RTH. Users can only control the speed and altitude of the aircraft. If the aircraft is in risk of collision, exit RTH immediately. Before each flight, it is important to set an RTH altitude that is appropriate for the given environment. Go to DJI MG > Operation View > ●●● >  > Set Return to Home Altitude.</p>
	<p>If the aircraft is flying under 15 meters and RTH (including Smart and Failsafe RTH) is triggered, the aircraft will first automatically ascend to 15 meters from the current altitude. You cannot control the aircraft during this ascent. In Smart RTH, you can exit RTH to cancel automatic ascent by pressing the RTH button once.</p>
	<p>The aircraft automatically descends and lands if RTH is triggered when the aircraft flies within a 20 m radius of the Home Point.</p>
	<p>The aircraft cannot return to the Home Point when GNSS signal is weak () or is unavailable.</p>
	<p>When the RTH altitude is set to more than 15 m and the aircraft is ascending between 15 m and the preset RTH altitude, the aircraft will stop ascending and immediately return to the Home Point if you push the throttle stick.</p>

Low Battery Warnings

There are two low battery warnings:

1. Low Battery Warning: The Aircraft Status Indicator slowly blinks red. Fly the aircraft back and land it as soon as possible, stop the motors, and replace the batteries.
2. Critical Battery Warning: the Aircraft Status Indicator rapidly blinks red. The aircraft will begin to descend and land automatically.



Users can set the threshold of both low battery level warnings.

RTK Functions (for MG-1S RTK only)

The MG-1S RTK has a built-in DJI Onboard D-RTK, which provides more accurate data for centimeter-level positioning to improve agricultural operation when using with DJI D-RTK Base Station. The aircraft's heading reference from the dual antennas of the onboard D-RTK is more accurate than a standard compass sensor and can withstand magnetic interference from metal structures.



Ensure to use RTK functions within the RTK data transmission distance. Refer to Specifications for details.

Enable/Disable RTK

Ensure that the "RTK Module" is enabled and RTK data source is correctly set (D-RTK Base Station) before each use. Go to Operation View in the DJI MG app > ●● > RTK > RTK Module to view and set.

Using with the DJI D-RTK Base Station

1. Refer to the D-RTK Base Station User Guide to complete linking between the aircraft and base station and setup of the base station.
2. Power on the base station and wait for the system to start searching for satellites. The RTK status icon on top of the Operation View in the DJI MG app will show  to indicate that the aircraft has obtained and used the RTK data from the base station.

Flight

Operation Environment

1. DO NOT use the aircraft in adverse weather conditions, such as heavy rain (precipitation rate exceeding 25 mm or 0.98 in within a 12-hour period), high winds exceeding 17 mph (28 kph), fog, snow, lightning, tornadoes, or hurricanes.
2. Only fly in open areas. Tall buildings and steel structures may affect the accuracy of the compass and the GNSS signal.
3. Maintain line of sight of the aircraft at all times, and avoid flying near obstacles, crowds, animals, trees, and bodies of water.
4. Avoid flying in areas with high levels of electromagnetism, including mobile phone base stations and radio transmission towers.
5. Ensure that there is a strong GNSS signal in the Smart or Manual Plus operation mode or F-mode.
6. DO NOT operate the aircraft indoors.
7. The MG-1S / MG-1S RTK cannot operate in P or F-mode within the earth's polar regions.

Flight Limits and No-Fly Zones

Users can set flight limits on height and distance.

Unmanned aerial vehicle (UAV) operators should abide by the regulations from self-regulatory organizations such as the International Civil Aviation Organization, the Federal Aviation Administration, and their local aviation authorities. For safety reasons, flight limits are enabled by default to help users operate this aircraft safely and legally.

When operating in P or F-mode, the height and distance limits and no-fly zones work together to monitor flight. In A-mode, only the height limit prevents the aircraft from going above 50 meters.

Maximum Height and Radius Limits

Users can change the maximum height and radius limits in the DJI MG app. Once complete, your aircraft will fly in a restricted cylinder that is determined by these settings. The tables below show the details of these limits.

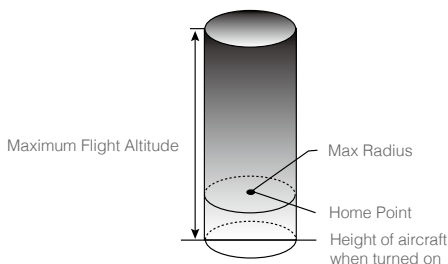

P-mode or F-mode (with strong GNSS signal)

Flight Limits

Max Height	Flight altitude must be below the preset height.
Max Radius	Flight distance must be within the max radius.

A-mode or other modes (with weak GNSS signal)	
Flight Limits	
Max Height	Flight altitude must be below the preset height.
Max Radius	No limits.

- ⚠ If you fly into a no-fly zone, you can still control the aircraft, but cannot fly it further.
- If the aircraft loses GNSS signal or is in A-mode and flies out of the max radius but regains GNSS signal or the flight mode is switched from A-mode to other modes (with strong GNSS signal) afterwards, it will fly back within range automatically.

No-Fly Zones

Detailed no-fly zones are listed on the DJI official website at <http://flysafe.dji.com/no-fly>. No-fly zones are divided into airports and restricted areas. Airports include major airports and flying fields where manned aircraft operate at low altitudes. Restricted areas include borders between countries or sensitive sites. The details of the no-fly zones are explained below (GNSS required):

R mi around the restricted area (depending on the regulation) is a no-fly zone, inside which takeoff and flight are prohibited.

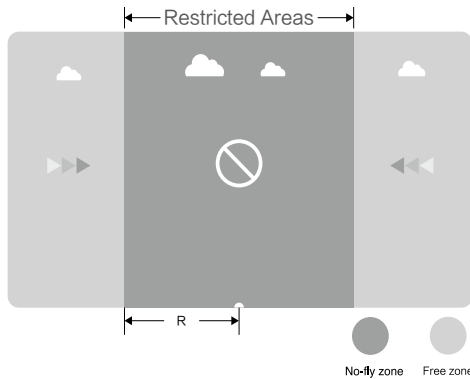

P-mode or F-mode (with strong GNSS signal)		
Zone	Restriction	Aircraft Status Indicator
No-Fly Zone ●	Motors will not start. If the aircraft loses GNSS signal or is in A-mode and enters the restricted area but regains GNSS signal or the flight mode is switched from A-mode to other modes (with strong GNSS signal) afterwards, the aircraft will enter semi-automatic descent and land.	Blinking Red 
Free Zone ●	No flight restrictions.	None.



Semi-Automatic Descent: All stick commands except the throttle stick command are available during descent and landing. Motors will automatically stop after landing.



- When operating in no-fly zones, the Aircraft Status Indicator will blink red slowly and continue for 5 seconds, then switch to indicate the current flying status and continue for 12 seconds, at which point it will switch back to blinking red slowly.
 - For safety reasons, DO NOT fly near airports, highways, railway stations, railway lines, city centers, or other busy areas. Ensure the aircraft is visible at all times.
-

Pre-Flight Checklist

1. The remote controller, aircraft battery is fully charged.
2. The pesticides required are adequate.
3. The position of aircraft battery is secured.
4. All parts are mounted securely.
5. All cables are connected correctly and firmly.
6. Propellers are unfolded and mounted onto the motors securely; frame arms are unfolded and arm sleeves are firmly tightened.
7. Spraying system is without any blockage.
8. Sprinkler hoses are clear from bubbles. Discharge bubbles, as they may lead to operation problems. Loosen the valve on the side of the spray nozzle and start the pump. Then tighten the valve and the sprinkler will work properly.

Calibrating the Compass

Because the aircraft's compass is highly sensitive, it requires calibration before your first flight and regularly to ensure optimal flight performance. Lack of calibration can lead to abnormal compass data, causing poor flight performance or failure.



- DO NOT calibrate your compass where there is a chance of strong magnetic interference, such as magnetite quarries, parking structures, and underground steel reinforcements.
 - DO NOT carry ferromagnetic objects such as cellular phones with you during calibration.
 - DO NOT calibrate near massive metal objects.
 - DO NOT calibrate in an indoor space.
-

Calibration Procedures

Choose an open space to carry out the following procedures. It is recommended to calibrate the compass with an empty tank.

1. Open the DJI MG app. Tap Start to enter Operation View. Tap the Aircraft Status Bar on top of the screen and select Calibrate in the Aircraft Status List, then follow the on-screen instructions.
2. Hold the aircraft upright and rotate it 360° along its central axis until the Aircraft Status Indicator changes from solid blue to solid green.
3. Hold the aircraft with its nose facing up and rotate it 360° along its central axis.

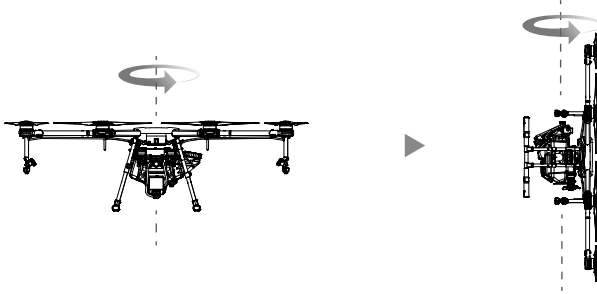

4. The Aircraft Status Indicator shows the current flight mode when calibration is complete. If the Aircraft Status Indicator blinks red, repeat the steps above to recalibrate the compass.

When to Recalibrate

1. Compass data is abnormal, and the Aircraft Status Indicator is alternately blinking red and yellow.
2. Flying in a new location, or a location that is different from your last flight.
3. The mechanical structure of the aircraft has changed.
4. Severe drifting occurs in flight (e.g., the aircraft has difficulty flying in a straight line).

Calibrating the Flow Meter

It is recommended to calibrate the flow meter before your first flight to ensure precision spraying.

- ⚠ • Ensure that bubbles in the hoses are completely discharged before calibrating.
- Fill the spray tank with 5-10 L water when calibrating. Use a standard measuring cup of 5 L volume to ensure accuracy.
- Perform calibration in Smart operation mode or F-mode, with an end-to-end flying distance of over 100 m.
- It is recommended to set the pesticide usage for spray to about 1.7 gal/ac.

Calibration Procedures

1. When calibrating the flow meter in F-mode, plan the field first. Refer to Intelligent Operation Planning System (p. 30) for more details.
2. Fill the spray tank with about 1 L of water.
3. Power on the remote controller and the aircraft.
4. Loosen the valve on the side of the sprinkler and press the Spray button on the remote controller until the DJI MG app indicates normal spraying. Press the Spray button to stop spraying and tighten the valve.
5. Empty the tank. Fill it with 5-10 L water.
6. Go to DJI MG > Operation View > ●●● > ⓘ, then tap Calibrate in Flow IMU settings. Enter the volume of the water in the tank. Be sure to input the precise value to avoid calibration bias. Tap ⓘ for calibration warnings.
7. When calibrating the flow meter in F-mode, start the task according to the Intelligent Operation Planning System.
If calibrating the flow meter in Smart operation mode, record Point A and B, confirm route according to Smart operation mode, and enter Continuous Smart operation mode.

- 8. The aircraft automatically sprays liquid and calibrates the flow meter.
- 9. The DJI MG app will display that calibration is complete. You may now begin regular operation.

- ☀️ • During calibration, tap ●●● > ⌂ to cancel. The accuracy of the flow meter will be the data before calibration.
- If you exit calibration before it is complete, data protection and operation resumption function are still available. Calibration will continue after resuming operation.

When to Recalibrate

1. Installing a different nozzle model. Note: choose the corresponding model in the DJI MG app after replacing nozzles. Go to Operation View > ●●● > ⌂ for configuration.
2. Using a liquid of a different viscosity.
3. The error between the actual value and the theoretical value of the completed area is more than 15%.

Starting and Stopping the Motors

Starting the Motors

The Combination Stick Command (CSC) listed below is used to start and stop the motors. Ensure you perform the CSC in one continuous motion. The motors will begin to accelerate to an idle speed. Release both sticks simultaneously. Take off immediately after the motors are spinning, or else the aircraft may lose balance, drift, or even takeoff by itself and risk damage or harm.



Stopping the Motors

There are two methods to stop the motors.

1. When the aircraft has landed, push the throttle down and hold. The motors will stop after three seconds.



2. When the aircraft has landed, push the throttle stick down, then perform the CSC command to stop the motors. Release both sticks once the motors have stopped.

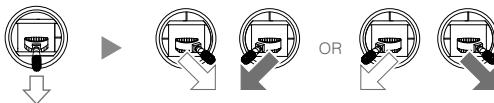

-
- ⚠ • Take off immediately after the motors are spinning, or else the aircraft may drift and cause damage or harm.
 - Rotating propellers can be dangerous. DO NOT start the motors in narrow spaces or when there are people nearby.
 - Always keep your hands on the remote controller when the motors are spinning.
 - If you perform the CSC when the aircraft is airborne, the motors will stop and cause the aircraft to crash. Never stop the motors mid-flight, unless in emergency situations when doing so can reduce the risk of damage or harm.
 - When using method 2 to stop the motors, the aircraft may tip if it doesn't touch the ground completely. Please use method 2 with caution. It is recommended to stop the motors via method 1.
-

Flight Test

1. Place the aircraft near the operation area with the Aircraft Status Indicator facing you.
2. Power on the remote controller. Connect the battery to the communication port, then the XT90 port.
3. Go to Operation View in the DJI MG app > ●●● >  > Connected DJI Device Type. Make sure to choose "MG-1S". Set the Flight Mode switch to P and the Operation Mode switch to M.
4. When using with the MG-1S RTK aircraft:

Ensure that the "RTK Module" is enabled and RTK data source is correctly set (D-RTK Base Station). Go to Operation View in the DJI MG app > ●●● > RTK > RTK Module to enable "RTK Module" and select the correct data source.

Make sure to disable "RTK Module" if RTK is not used. Otherwise, the aircraft cannot take off when there is no RTK data.
5. When the GNSS signal is strong, perform the CSC command to start the motors.
6. Push the throttle stick up to take off.
7. Select the desired operation or flight mode and spray liquid.
8. Exit the task to manually control the aircraft for landing. Hover over a level surface and gently pull down on the throttle stick to slowly descend.
9. After landing, push the throttle down and hold. The motors will stop after three seconds.
10. Disconnect the battery from the XT90 port, then the communication port. Power off the remote controller.

-
- ⚠ • When the Aircraft Status Indicator rapidly blinks yellow during flight, the aircraft has entered Failsafe mode.
 - The low battery level warning is triggered when the Aircraft Status Indicator slowly blinks red. Fly the aircraft back and land it as soon as possible, stop the motors, and replace the battery. The critical low battery level warning is triggered when the Aircraft Status Indicator rapidly blinks red. The aircraft will begin to automatically descend and land.
-

DJI Assistant 2

Configure settings of the remote controller and flying parameters, copy flight records, use the flight simulator, and update aircraft firmware in the DJI Assistant 2 app.

Installation and Launching

1. Download the DJI Assistant 2 installation file from the MG-1S download page:
<http://www.dji.com/mg-1s/info#downloads>
2. Install the software.
3. Launch DJI Assistant 2.

Using DJI Assistant 2

Connect the Micro USB port of the aircraft to your computer with a Micro USB cable. Then power on the aircraft.



Be sure to remove the propellers before using DJI Assistant 2.

Dashboard

Check all basic settings on this page. Click the blue hyperlinks for detailed settings.

Basic Settings

Remote Controller

Configure channel mapping and calibrate the remote controller.

ESC

Configure idle speed of and test the motor.

Flight Settings

Power

Basic gain and power bandwidth settings. It is recommended to use the default settings.

Gain

Advanced gain and sensitivity gain settings. It is recommended to use the default settings.

Failsafe Settings

Select the Failsafe action of the aircraft between hover and RTH, set RTH altitude (not beyond the maximum altitude) and the aircraft's heading during RTH.

Battery

Configure the threshold and the aircraft actions of low battery warnings.

Flight Restriction

Set the maximum altitude (up to 50 m). Enable or disable distance limit and set the value (up to 1000 m).

Tools

Topology

View system status and error information. Click the A3 flight controller icon to enter IMU calibration. View and calibrate IMU status.

Flight Record

Enter SD card mode and copy the flight record.

Backup

Backup and restore the flight controller settings.

Simulator

Click Open to enter flight simulation and practice flight. Click Start Simulation and aircraft attitude data (e.g., roll, pitch, yaw) will be shown on the right of the screen.

Firmware Update

A DJI account is required for firmware updates. Login with your DJI account or register for one.

Radar

Shows radar module information in order to fix any issues. If the module is connected, Software version, hardware ID, loader, and other information will be shown. If not connected, the information above will not appear.

Appendix

Specifications

Airframe

Diagonal Wheelbase	1515 mm
Frame Arm Length	625 mm
Dimensions	MG-1S: 1471 mm × 1471 mm × 482 mm (Frame arms unfolded, propellers removed) 780 mm × 780 mm × 482 mm (Frame arms folded)
	MG-1S RTK: 1471 mm × 1471 mm × 522 mm (Frame arms unfolded, propellers removed) 780 mm × 780 mm × 522 mm (Frame arms folded)

Propulsion System

Motors

Stator Size	60×10 mm
KV	130 rpm/V
Max Thrust	5.1 kg/rotor
Max Power	770 W
Weight (With cooling fan)	280 g

ESCs

Max Allowable Current (Continuous)	25 A
Operating Voltage	50.4 V(12S LiPo)
Signal Frequency	30 - 450 Hz
Drive PWM Frequency	12 kHz

Foldable Propeller

Material	High-performance engineered plastics
Diameter × Pitch	21×7 inch
Weight	58 g

Spraying System

Spray Tank

Volume	10 L
Standard Operating Payload	10 kg
Max Battery Size	151 mm×195 mm×70 mm

Sprinklers

Model	XR11001
Quantity	4
Max Spray Rate	0.45 L/min (Single nozzle, using water)
Spray Width	4 - 6 m (4 nozzles, 1.5 – 3 m above the crops)
Droplet Size	130 - 250 μm (Depending on operating environment and spraying speed)

Radar Terrain Follow System

Detection Range	1 - 5 m (Varies when flying above different kinds of vegetation)
Working Range	1.5 - 3.5 m
Detection Accuracy	< 10 cm

Flight Parameters

Total Weight (Excluding battery)	MG-1S: 10 kg, MG-1S RTK: 10.2 kg
Standard Takeoff Weight	23.8 kg
Max Takeoff Weight	24.8 kg (At sea level)
Max Thrust-Weight Ratio	1.71 (Takeoff weight of 23.8 kg)
Hovering Accuracy (P-mode or F-mode, strong GNSS signal)	D-RTK enabled: horizontal ± 10 cm, vertical ± 10 cm D-RTK disabled: horizontal ± 0.6 m, vertical ± 0.3 m (0.1 m, Radar Terrain Follow System enabled)
GNSS*	GPS+GLONASS
Battery	DJI approved battery pack (Model: MG-12000)
Max Power Consumption	6400 W
Hovering Power Consumption	3800 W (Takeoff weight of 23.8 kg)
Hovering Time*	22 min (Takeoff weight of 14 kg with a 12000 mAh battery)
	10 min (Takeoff weight of 23.8 kg with a 12000 mAh battery)
Max Operating Speed	7 m/s
Max Flying Speed	12 m/s (P-mode or F-mode, with GNSS), 15 m/s (A-mode)
Max Service Ceiling Above Sea Level	2000 m
Operating Temperature	32° to 104° F (0° to 40° C)











RTK Module (for MG-1S RTK only)





GNSS Frequency	Mainland China/South Korea: GPS L1&L2, BEIDOU B1&B2 CE/FCC: GPS L1&L2, GLONASS F1&F2
Communication Frequency Band	Mainland China: 430–432 MHz South Korea: 447.8625–447.9875 MHz CE: 869.525 MHz FCC: 903–925.5 MHz
Max Transmission Range	Mainland China/South Korea/CE: 300 m FCC: 500 m (Unobstructed and free of interference with a height of 3.2 m from the D-RTK antenna to the end of the tripod and the aircraft flying above the vegetation at 1.5 m)
EIRP	Mainland China/South Korea: 10 dBm CE: 13 dBm FCC: 27dBm

* For the Asia-Pacific version of the MG-1S RTK, GNSS is GPS+GLONASS+BEIDOU when RTK is enabled. Estimated hovering time was measured at sea level and in wind speeds under 3 m/s. This value should be used for reference only.

Remote Controller	
Model	DLG60A
Operating Frequency	2.400 GHz to 2.483 GHz
Max Transmission Range	FCC: 1.5 km, CE/KCC/TELEC/SRRC: 1 km (Unobstructed and free of interference)
EIRP	FCC: 24 dBm, CE/KCC/TELEC/SRRC: 19 dBm
Built-in Battery	6000 mAh, 2S LiPo
Display Device	5.5 inch screen, 1920×1080, 1000 cd/m ² , Android system, 4G RAM+16G ROM
Output Power	7 W
Operating Temperature	14° to 104° F (-10° to 40° C)
Storage Temperature	Less than 3 months: -4° to 113° F (-20° to 45° C) More than 3 months: 72° to 82° F (22° to 28° C)
Storage Temperature	41° to 104° F (5° to 40° C)
Remote Controller Charger	
Model	A14-057N1A
Voltage	17.4 V
Rated Power	57 W

Aircraft Status Indicator Description

Blinking Patterns	Description
 Blinking Red, Green and Yellow	Self-checking
 ×4 Blinking Yellow for 4 times	Warming up
 Slowly Blinking Purple	P-mode (GPS)
 Slowly Blinking Yellow	A-mode or P-mode/F-mode (no GPS)
 Slowly Blinking Green	F-mode (GPS)
 — Solid Red	System error. Restart the aircraft, if still not working, contact DJI Support or a DJI authorized dealer.
 Alternately Blinking Red and Yellow	Abnormal compass data, compass calibration required
 Rapidly Blinking Red Several Times	Point A recorded
 Rapidly Blinking Green Several Times	Point B recorded
 Rapidly Blinking Blue Several Times	The aircraft flies to the next turning point in Smart Operation Mode.
 — Solid Purple for one second	Entered Continuous Smart Operation Mode

	Rapidly Blinking Yellow	Remote controller signal lost
	Slowly Blinking Red	Low battery level
	Rapidly Blinking Red	Critical low battery level
	Solid Green	System Data Protection function working

Upgrading the Firmware

Aircraft Firmware

Connect the Micro USB port of the aircraft to DJI Assistant 2 on your computer to update the aircraft firmware. Refer to the [DJI Assistant 2 \(p. 48\)](#) section for details.

Remote Controller Firmware

Power on the remote controller and update the remote controller firmware in the DJI MG app.

1. Enter Operation View > System Status bar > Aircraft Status List to check the current firmware version. Follow the instructions in the DJI MG app to finish the update if there is a new version.
2. The Status LED will turn solid green when the update is successful. The LED will turn solid red if the update fails. Restart the remote controller and try again.



- The firmware update process takes approximately 10 minutes. We recommend finding a comfortable environment to carry out the update.
- Both the remote controller and aircraft firmware must be up-to-date, or else they will not link.
- Check the DJI MG app that you have the latest firmware installed before every flight.
- The firmware update requires an internet connection. Connect the display device to a Wi-Fi network whenever possible.
- Wait for the progress bar to reach 100% to ensure that the firmware update is complete.
- The remote controller status indicator glows solid blue during the update.
- DO NOT power off the remote controller during the update.
- DO NOT perform the firmware update while the aircraft is in the air. Only carry out the firmware update when the aircraft is on the ground.
- The remote controller may become unlinked from the aircraft after the firmware update. Relink the remote controller and aircraft if necessary.

DJI Support
<http://www.dji.com/support>

This content is subject to change.

Download the latest version from
<http://www.dji.com/product/mg-1s>

If you have any questions about this document, please contact DJI by sending a message to DocSupport@dji.com.

AGRAS is a trademark of DJI.
Copyright © 2017 DJI All Rights Reserved.

